

A heavy-duty system for P&F conveyors. Reduces labor and saves money by cutting downtime and protecting conveyor components.

Features/Benefits

- The OP-317 system lubricates sealed side guide rollers while the conveyor is running under normal conditions
- Reduces downtime and manual labor operations in lubricating conveyor free trolley guide rollers
- Rollers that are lubricated properly can extend the life of conveyor components
- Eliminates surging and drag caused by non-lubricated rollers, so product can be spaced closer, increasing productivity
- Conveyor runs smoother, keeps product from swaying, reducing possibility of injury on the line
- Helps to reduce drive power requirements
- Less waste. A metered amount of lubricant is cleanly and precisely injected into rollers
- The right lubrication system results in a clean operation – and saves you substantial amounts of time, work and money
- For Overhead or Inverted conveyors

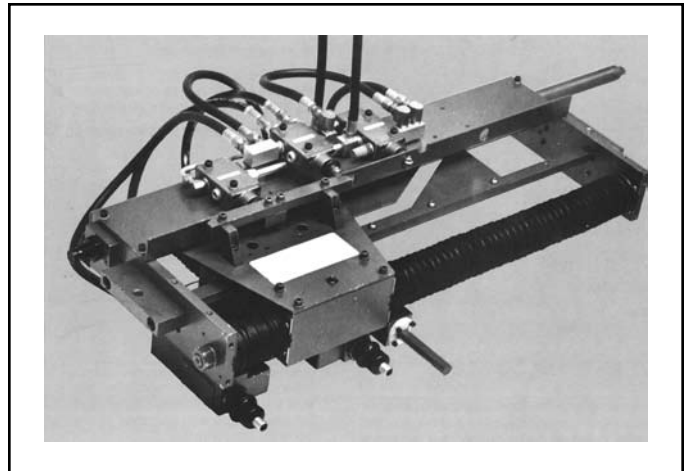

SPECIFICATIONS	
Lubricant	Oil: 22 cST@40°C and higher; Grease up to and including NLGI No. 2. Lubricants with solid additives must be colloidal < 5 Microns
Shot Volume	0.025 cu.in. (0.41 cm ³) per coupler
Lubricant Pump	Pneumatic 50:1 lubricant supply cover pump w/cover and follower plate for 5 gal, standard; 16 gal, optional; or 55 ga optional
Input Power	110 VAC, 60Hz, standard; 110 VAC, 50Hz, optional; 220 VAC, 60Hz, optional; 220 VAC, 50Hz, optional; 24 VDC, optional
Plant Air Pressure Required	80 psi (6 bar), minimum
Ambient Temperature	60°F to 120°F (15°C to 50°C)
Dimensions	Envelope size, 48in L x 40in W x 48in H (122 cm L x 102 cm W x 122 cm H) from bottom of hoses to top of open control enclosure
Shipping Weight	200 lbs (90.8 kgs)
Conveyor Speed	Nominal range, 10 to 60 ft/min (3 to 18 meters/min), range may vary depending on wheel diameter and trolley spacing, consult OPCO for details

OP-317 Assemblies

The OP-317 system consists of a controls assembly, a trolley lubricating assembly and a lubricant supply pump assembly.

Controls Assembly – lubricant filter, pressure regulator, airline filter regulator, and electrical control system.

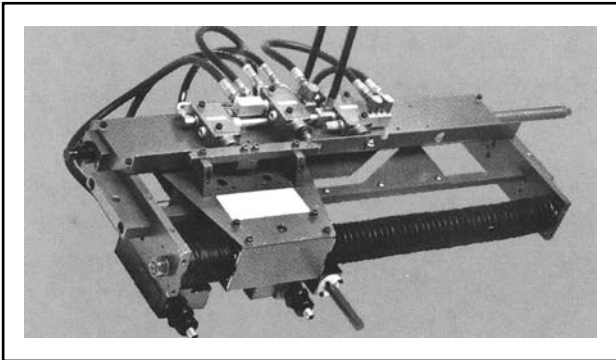

Trolley Assembly – lubricant injectors (couplers), side guide roller locator, and controls to synchronize lubricator operation with conveyor movement.

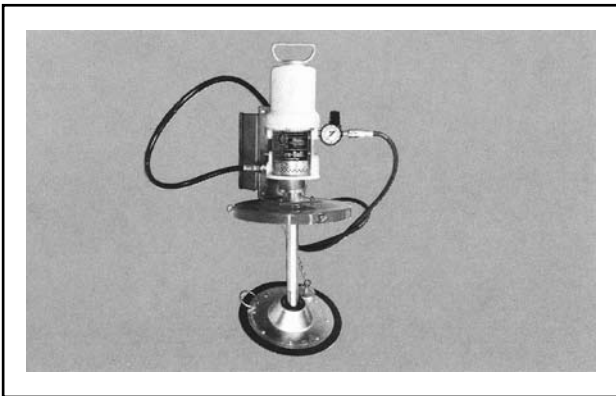

Pump Assembly – 50:1 pneumatically operated pump, container cover and follower plate, air inlet and grease outlet, and lube supply fault assembly.

OP-317 System Operation

The OP-317 system is designed to lubricate free trolley sealed side guide rollers. The system injects a metered amount of lubricant into the guide roller bearings, without interrupting manufacturing schedules. The system will dispense grease or oil. Lubricant is supplied to the unit by a pump which may be placed at floor level for added convenience.

Lubrication takes place during normal conveyor operation. The duration of the lube cycle can be manually controlled or electrically controlled by a timer, an electronic counter, or other electrical control. Trolleys can be unevenly spaced.

Standard Components

- One automatic lube head assembly with two couplers, to lubricate two side guide rollers simultaneously
- Airline preparation equipment – airline filter regulator with gauge
- Lubricant supply pump – pneumatic 50:1 lubricant supply pump with cover and follower plate for 35# (5 gal) pail
- Lubricant filter – with removable element for cleaning or replacement
- Protective bellows – protect areas subject to increase wear due to contamination by abrasive materials in the atmosphere
- Lube supply fault indicator, output contact and shut-off circuit

Optional Equipment

- ChainMaster Lubricator Controller for precise lube cycle frequency control
- 12-hour timer for manual-on and automatic-off operation. System shuts off automatically at the end of the lube cycle
- 1000-hour fully automatic high-resolution repeat cycle timer
- PC interface relay and 3-position switch
- Additional mounting frame – complete with controls. Available for additional conveyors that are the same size. Trolley assemblies can be moved from one conveyor to another for portable convenience

Sequence of Operation

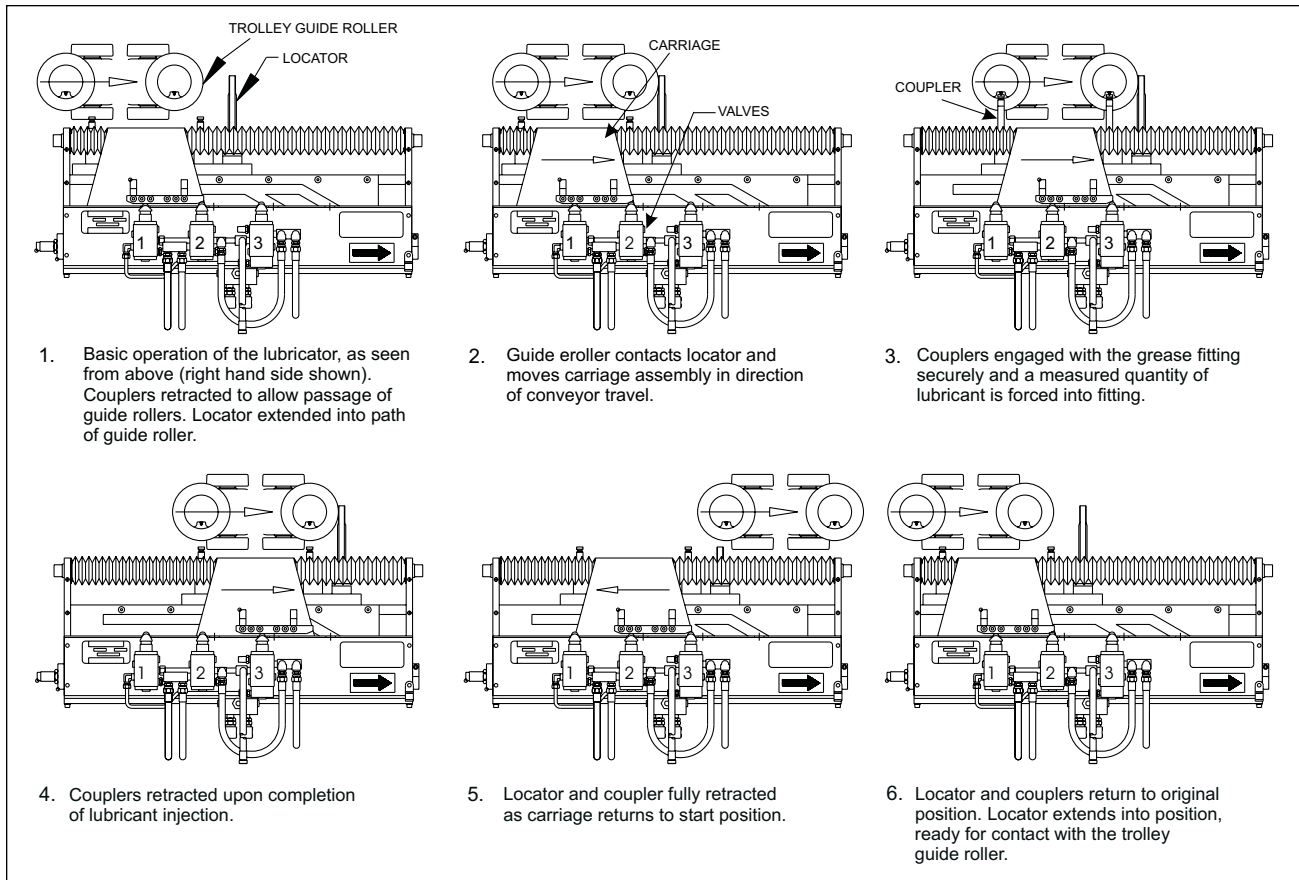

Technical Assistance

Customized Technical Assistance Programs are available.

Warranty

A limited warranty is provided with each OP-317 lubricator.

WearMaster Lubricants – Specially Designed for Conveyor System Lubrication

OPCO has a complete line of Conveyor lubricants, for all conveyor applications, designed to keep you system running smoothly. Using the right lubricant for the application can save money otherwise lost to wear, increased power consumption, and unscheduled downtime.

Recognized worldwide as lubrication systems specialists, we have years of experience in every aspect of conveyor lubrication - from equipment design, sales and installation to lubricant sales, systems service, consultation and custom problem-solving. As a result, we're familiar with your needs and concerns. We can supply you with the WearMaster lubricants that will provide the best results in your conveyor system.